

53TM SERIES STAINLESS STEEL TOP MOUNT WASTE CONTAINER

TOOLS REQUIRED:



ESTIMATED ASSEMBLY TIME:

20 MIN
WATCH TUTORIALS OF OUR PRODUCTS BEING INSTALLED



WWW.REV-A-SHELF.COM/VIDEOS

CARE AND MAINTENANCE:

CLEAN WITH A DAMP CLOTH AND WIPE PARTS DRY

Parts List

No.	Description	Qty
1	Metal Box	1
2	Lid	1
3	Slides	2
4	Slide Covers	2
5	Lid Holders	2
6	Door Mounting Brackets	2
7	Door Mounting Covers	2
8	Plugs	4
9	Waste Bins	2
10	#8x1/2" Pan Head Screws	12
11	#8x5/8" Flathead Screws	8
12	M4x5 Machine Screws	4
13	#6x1/2" Flathead Screws	6
14	1/4-28x1/2" Machine Screws	2

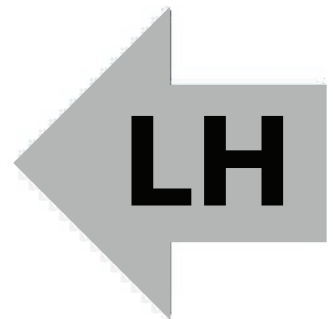
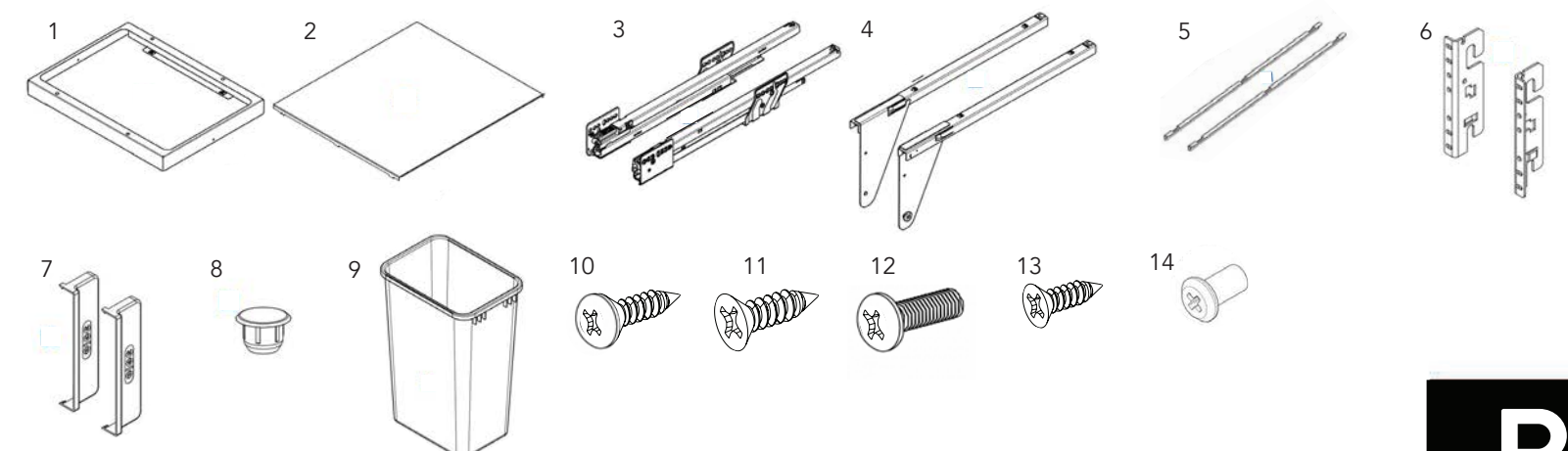

STEP 1

Place template and mark hole locations for the left hand slide. Then attach each lid holder slide using (3) #8x1/2" pan head screws and each slide using (4) #8x5/8" flathead screws (See Figure 1). Flip the template and do the same for the right hand slide.

FIGURE 1

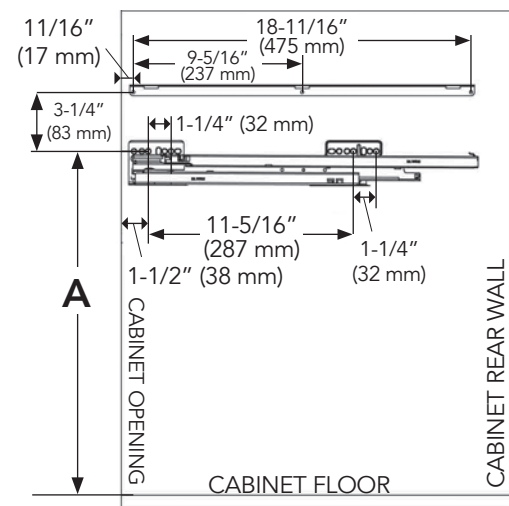

STEP 2

Place the slide covers over the slides (See Fig 2).

FIGURE 2

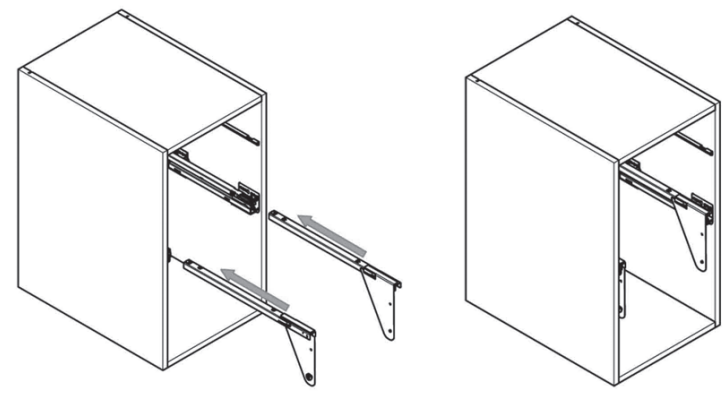

STEP 3

Extend the slides and mount the metal box using the (4) M4x5 machine screws (See Fig 3).

FIGURE 3

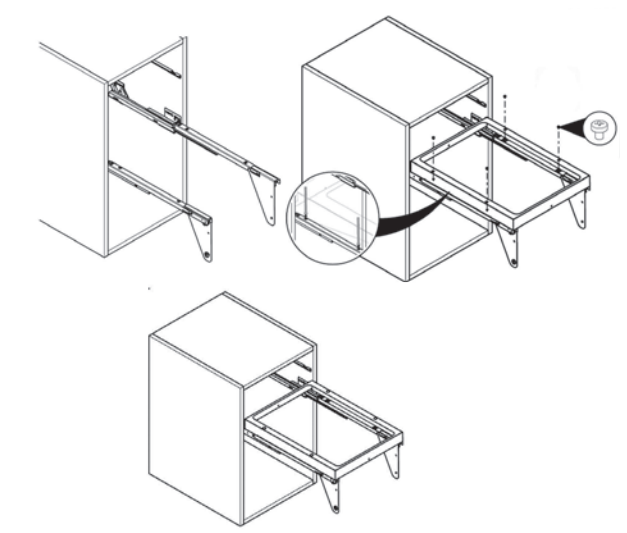

STEP 4

Place the (4) plugs over the cylindrical screws (See Fig 4).

FIGURE 4

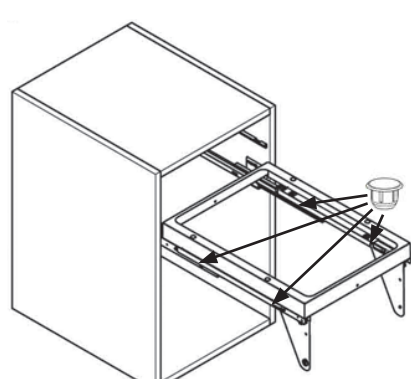

STEP 5

Mark and pre-drill mounting holes using measurements in figures 5 and 6. Attach door mounting brackets using (6) #6x1/2" flathead screws.

FIGURE 5

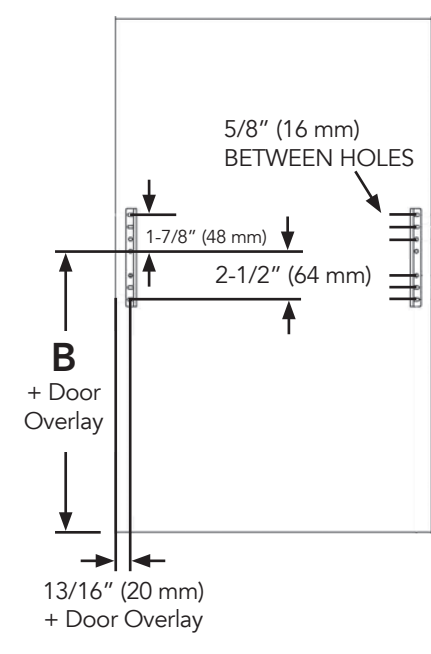

HOW TO DETERMINE YOUR DOOR OVERLAY:

Measure Opening Height _____
Measure Door Height _____
Height Difference _____
Divide Difference by 2 _____ = Overlay

FIGURE 6

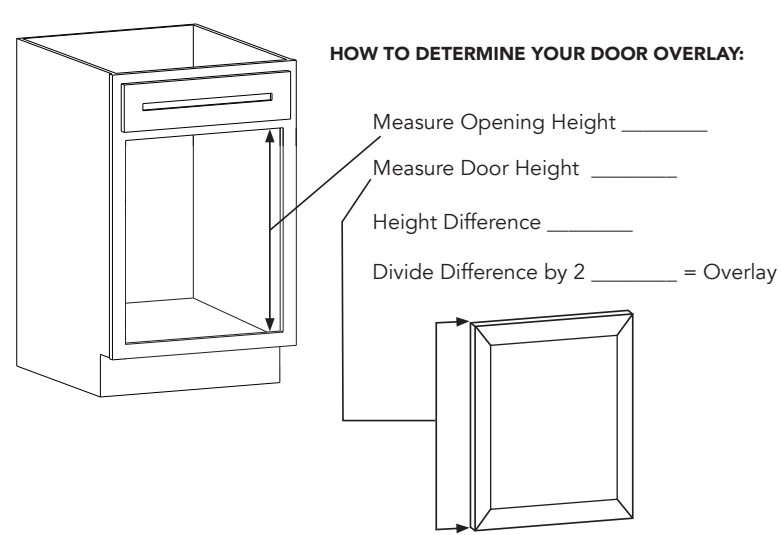

Part Number	B
53TM-1835GSCDM2-FL	10-7/8" (277 mm)
53TM-1850GSCDM2-FL	14-7/8" (378 mm)
53TM-18GSCDM3-FL	11-1/8" (282 mm)
53TM-24GSCDM4-FL	11-11/16" (297 mm)

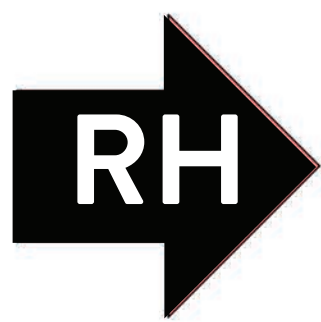
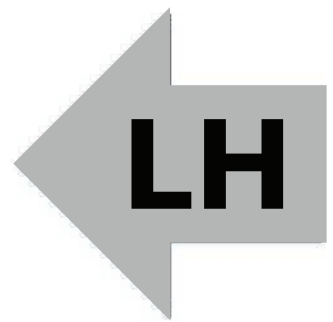

STEP 6

Align the door brackets to the slide covers and attach with (2) 1/4-28x1/2" machine screws and washers (See Fig 7).

FIGURE 7

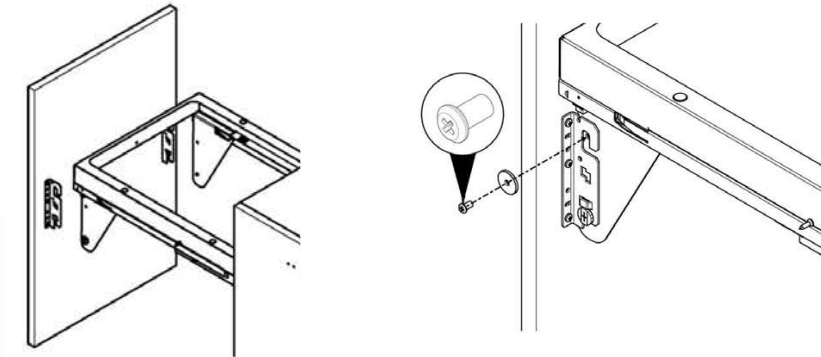

STEP 7

Adjust the door using the adjustment screws (See Fig 8) until the door is centered and flush with your frame.

FIGURE 8

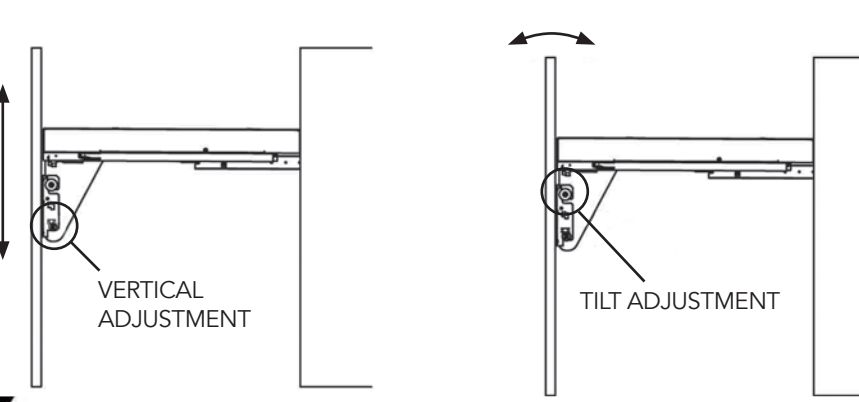

35qt BINS

STEP 8

Place the door mount covers over the door mount brackets (See Fig 9).

FIGURE 9

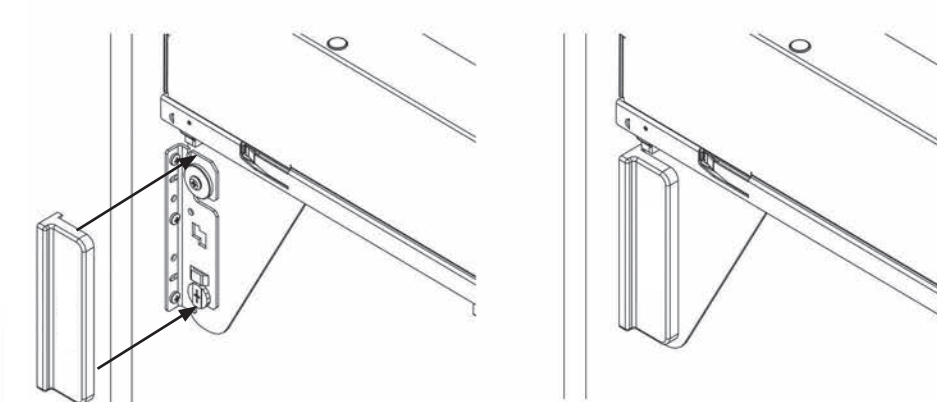

STEP 9

Place the lid on the holders and insert waste bins (See Fig 10).

FIGURE 10

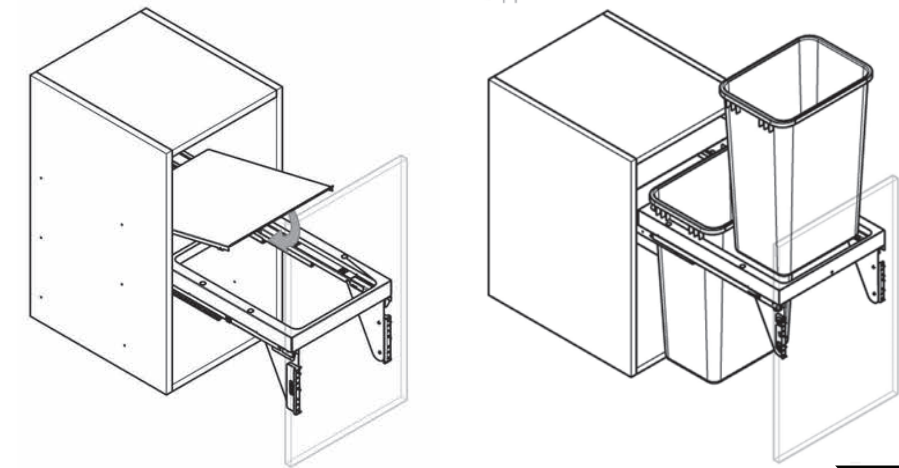

50qt BINS

MONTAJE SUPERIOR DE CONTENEDOR DE BASURA DE ACERO INOXIDABLE DE LAS SERIES 53TM POUBELLE EN ACIER INOXYDABLE DE LA SERIE 53TM AVEC MONTAGE PAR LE HAUT



Tiempo estimado de ensamblado
Durée de l'installation:

20 MIN
VER VIDEOS DE
INSTALACIONES DE PRODUCTOS
REGARDER DES VIDÉOS
D'INSTALLATIONS DE PRODUITS

WWW.REV-A-SHELF.COM/VIDEOS

Cuidado/ Entretien:

Limpie con un paño húmedo y seque las partes. Lubrique los puntos de los pivotes como sea necesario.

Nettoyer avec un chiffon humide et essuyer pour sécher complètement. Lubrifiez les points de pivotement si nécessaire

LISTA DE PARTES / LISTE DES PIÈCES

Descripción / La description	#
1 Caja Metálica / Boîte en métal	1
2 Tapa / Couvercle	1
3 Deslizantes / Coulissses	2
4 Cubiertas Deslizantes / Couvercles des coulisses	2
5 Sujetadores de la Tapa / Supports de couvercle	2
6 Soportes de Montaje para Puerta / Supports de Montage de Porte	2
7 Cubiertas de Montaje para Puerta / Couvercles de Montage de Porte	2
8 Tapones / Fiches	4
9 Contenedores de Basura / Poubelles	2
10 Tornillos de Cabeza de Sartén del #8x1/2" / Vis à tête cylindrique #8x1/2"	12
11 Tornillos de Cabeza plana del #8x5/8" / Vis à tête plate #8x5/8"	8
12 Tornillos de Máquina M4x5 / Vis machine M4x5	4
13 Tornillos de Cabeza Plana del #6x1/2" / Vis à tête plate #6x1/2"	6
14 Tornillos de Máquina de 1/4-28x1/2" / Vis machine 1/4-28x1/2"	2

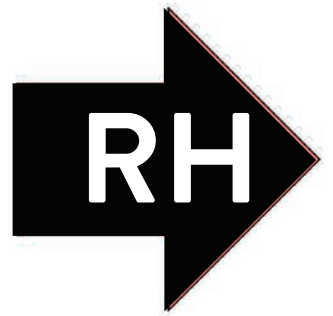
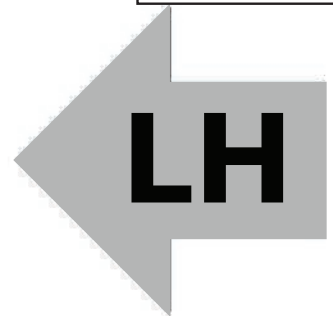
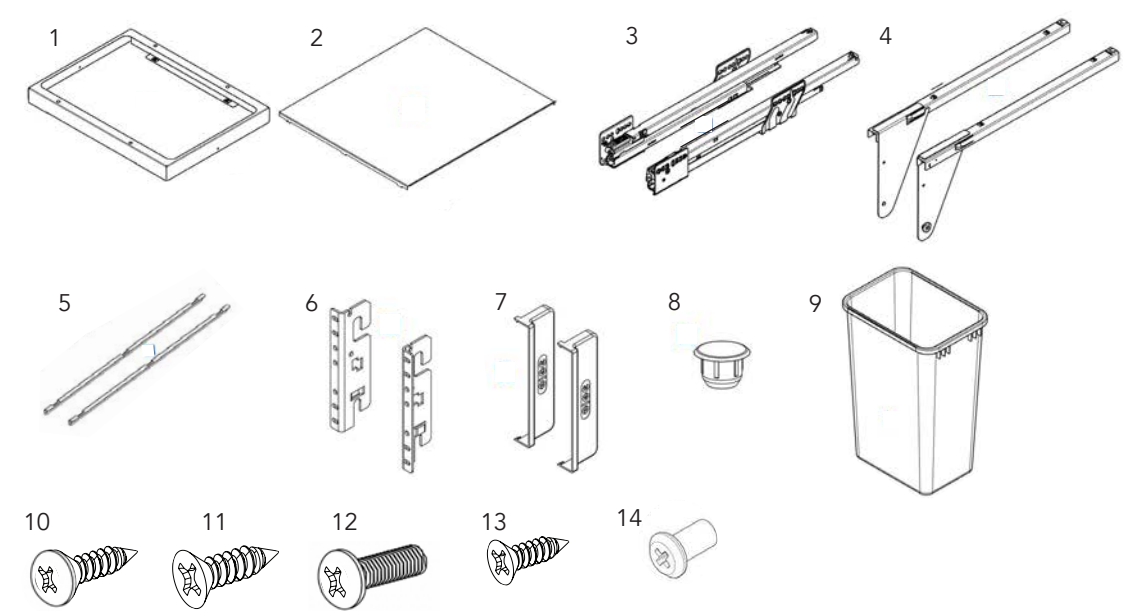
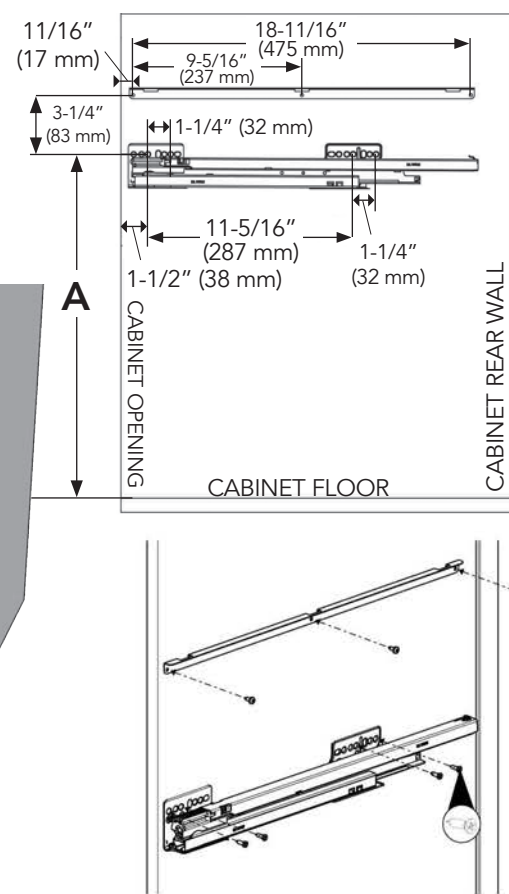

FIGURE 1



PASO 1 / ÉTAPE 1

Coloque la plantilla y marque las ubicaciones de los orificios para la guía superior izquierda. Luego, sujete cada sujetador de la tapa usando tres tornillos de cabeza de sartén del #8x1/2" y cada deslizante usando cuatro tornillos de cabeza plana del #8x5/8" (véase la Figura 1). Gire la plantilla y realice lo mismo con la guía inferior derecha.

Placer le gabarit et marquer l'emplacement des trous pour la glissière supérieure gauche. Ensuite, fixez chaque support de couvercle avec 3 vis à tête cylindrique #8x1/2" et chaque coulisse avec 4 vis à tête plate #8x5/8" (voir figure 1). Retourner le gabarit et faire de même pour la glissière droite inférieure.



PASO 2 / ÉTAPE 2

Coloque las cubiertas deslizantes sobre los deslizantes (ver la figura 2).

Placez les couvercles des coulisses sur les coulisses (voir l'illustration 2)

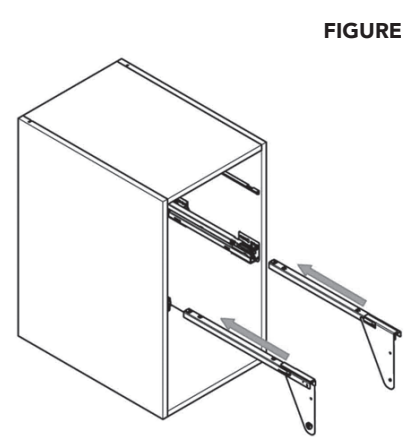

PASO 3 / ÉTAPE 3

Extienda los deslizantes y monte la caja metálica usando los cuatro tornillos de máquina M4x5 (ver la figura 3).

Étendez les coulisses et montez la boîte en métal avec les 4 vis machine M4x5 (voir l'illustration 3).

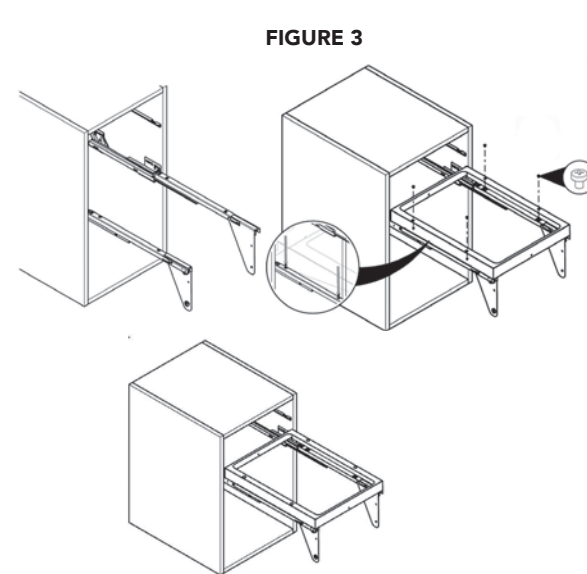

FIGURE 3

PASO 4 / ÉTAPE 4

Coloque los cuatro tapones sobre los tornillos cilíndricos (ver la figura 4).

Placez les 4 fiches sur les vis cylindriques (voir l'illustration 4).

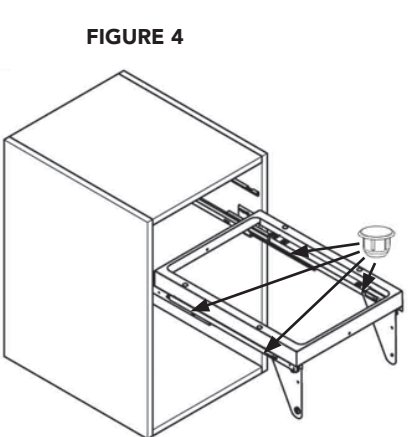

FIGURE 4

PASO 5 / ÉTAPE 5

Marque y pre taladre orificios de montaje usando las medidas en las figuras 5 y 6. Sujete los soportes de montaje usando seis tornillos de cabeza plana del #6x1/2".

Marquez et pré-percez les trous de montage en utilisant les mesures des illustrations 5 et 6. Fixez les supports de montage de porte avec 6 vis à tête plate #6x1/2".

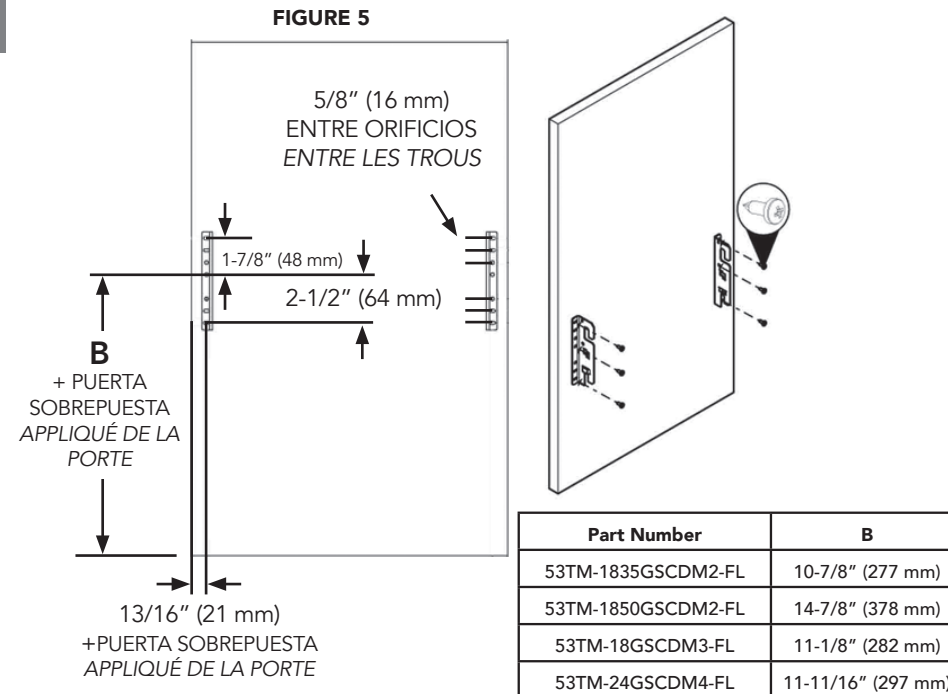
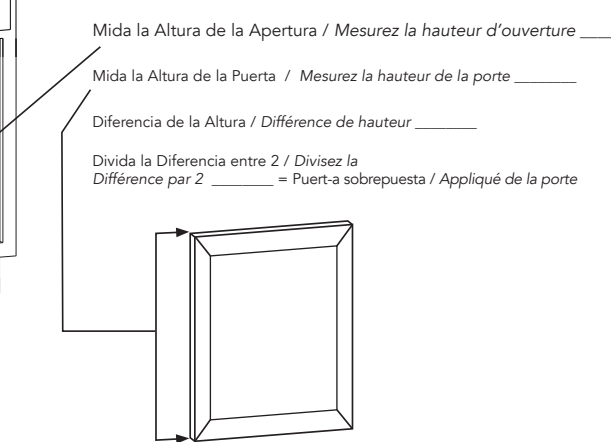

FIGURE 5

FIGURE 6
CÓMO DETERMINAR LA PUERTA SOBREPUESTA:
COMMENT DÉTERMINER VOTRE APPLIQUÉ DE PORTE:



PASO 6 / ÉTAPE 6

Alinee los soportes de la puerta a las cubiertas de los deslizantes y sujete con dos tornillos de máquina de 1/4-28x1/2" y con arandelas (ver la figura 7).

Alignez les supports de porte aux couvercles des coulisses et fixez avec 2 vis 1/4-28x1/2" et rondelles (voir l'illustration 7).

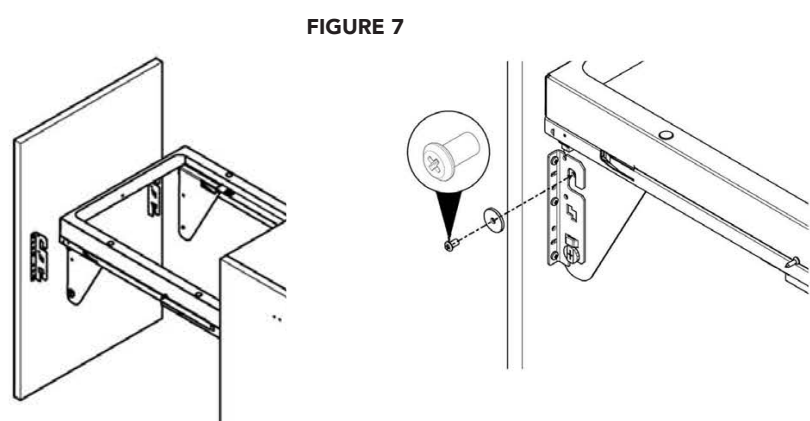

FIGURE 7

PASO 7 / ÉTAPE 7

Ajuste la puerta usando los tornillos de ajuste (ver la figura 8) hasta que la puerta esté centrada y al ras con el marco.

Réglez la porte avec les vis de réglage (voir l'illustration 8) jusqu'à ce que la porte soit centrée et alignée avec votre cadre.

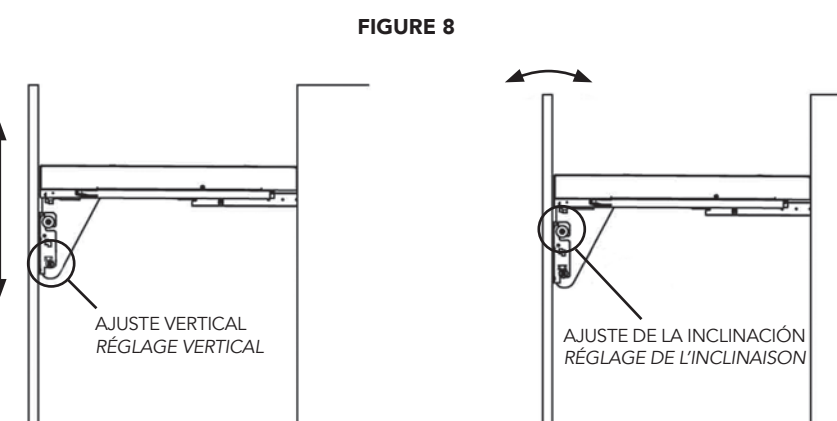

FIGURE 8

35qt BINS

PASO 8 / ÉTAPE 8

Coloque las cubiertas de montaje de la puerta sobre los soportes de montaje de la puerta (ver la figura 9).

Placez les couvercles de montage de porte sur les supports de montage de porte (voir l'illustration 9).

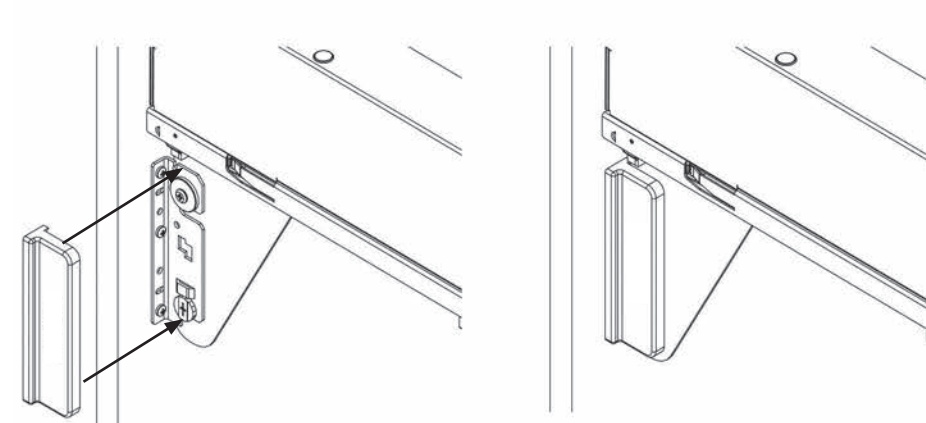

FIGURE 9

PASO 9 / ÉTAPE 9

Coloque la tapa sobre los sujetadores e inserte los contenedores de basura (ver la figura 10).

Placez le couvercle sur les supports et insérez les poubelles. (Voir l'illustration 10).

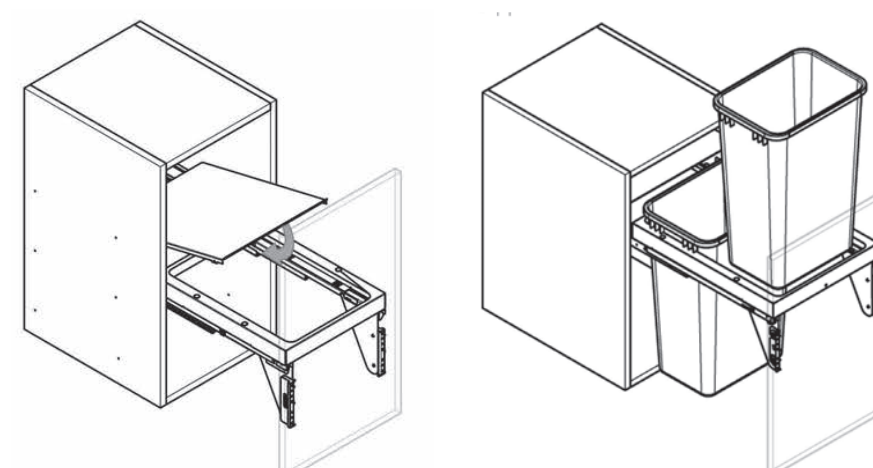

FIGURE 10

50qt BINS