

# Wyndham 1 Door 2 Drawer Vanity



## Specifications

- Durable white thermofoil finish with satin nickel hardware
- Cam lock connection, frameless design
- California 93120 CARB P2 compliant
- Ready to assembly construction
- Square raised door
- Durable white thermofoil door and drawer front
- Particle board with white PVC inside and outside side panels
- 1 Door 2 drawer 1 fake drawer design
- Door and drawer reversible during assembly
- Adjustable and concealable hinge, easy glide drawer glides
- Satin Nickel hardware with TruMatch finish

Vanity top and faucet sold separately



## Dimensions

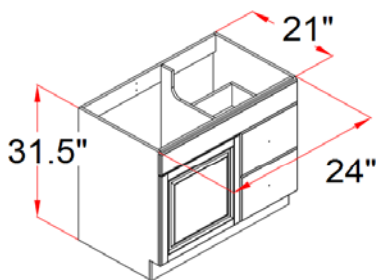

545053

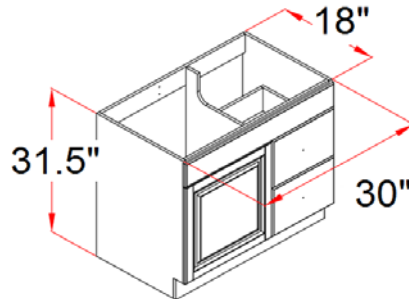

545061

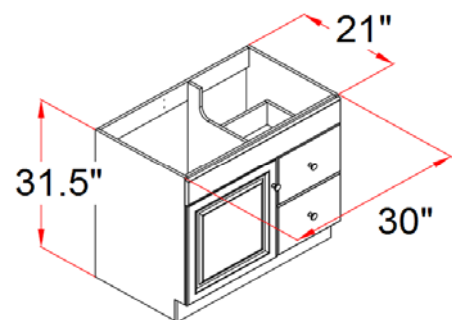

545079

## Warranty & Compliances

- Warranty** Limited 1 year warranty
- California 93120** CARB P2 compliant



## Order Codes & Finishes/Colors

24" w x 21" d x 31.5" h	545053
30" w x 18" d x 31.5" h	545061
30" w x 21" d x 31.5" h	545079

Type:

Job:

Order Code:

Approvals:

Design House reserves the right to make changes in materials, specifications & models at any time. Design House also reserves the right to discontinue product without notice or obligation.