

PART NO.	'NOM DIM'	SHELF DEPTH	LENGTH 'A'	DIM 'B'	DIM 'C1'	DIM 'C2'	DIM 'C3'	DIM 'D'	HOLES 'E'	LUG PRS 'F'
B01-56051-WH4	5"	6"	5.27	4.83	.49	1.37	----	1.93	2	2
B01-56071-WH4	7"	8"	7.26	6.83	.49	1.44	----	1.93	2	2
B01-56091-WH4	9"	10"	9.23	8.80	.51	1.38	----	1.93	2	2
B01-56101-WH4	10.5"	12"	11.20	10.76	.52	1.42	----	1.93	2	2
B01-56121-WH4	12.5"	14"	13.17	12.74	.53	1.44	----	1.93	2	2
B01-56141-WH4	14.5"	16"	15.18	14.74	.73	2.50	----	3.20	2	3
B01-56181-WH4	18.5"	20"	19.01	18.57	.64	1.74	2.85	3.20	3	3
B01-56241-WH4	24.5"	24"	24.51	24.07	.56	1.63	2.72	3.20	3	3

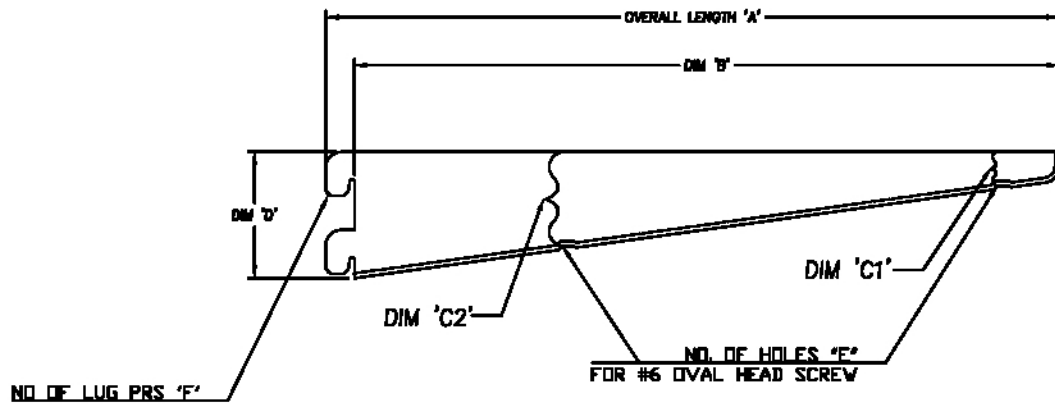

DIM 'C3', THIRD HOLE, AND THIRD LUG PAIR NOT ILLUSTRATED

# APPLICATION DRAWING

CUSTOMER P/N (IF APPLICABLE)	REV.
------------------------------	------

THIS PRINT IS THE PROPERTY OF RPC AND ITS DUPLICATION, RETENTION OR TRANSMITTAL TO OTHERS IS PROHIBITED WITHOUT PRIOR CONSENT.



ECR#	REV.	DESCRIPTION	BY	DATE

MATERIAL SEE CHART WHITE POWDER COAT FINISH		SCALE (SIZE) 1:1	SHT NO. 1 OF 1
FILENAME B0156XX1APP	CHKD BY DATE	PART DESCRIPTION PREMIER DBL BRKT, SHELF SUP.	
DRAWN BY CWW	DATE 9/5/12	PART NUMBER B01-56XX1-APP	REV.