

Features and Specifications:

- Bar/prep sink.
- Made of 80% quartz and the finest acrylic resins.
- Designed for undermount installation in all solid surface, granite and quartz countertops.
- Outside dimensions: 16-5/8" x 16-5/8" x 8-1/4".
- Waste opening: 3-1/2".
- Sink bowl surface has a matte finish.
- Supplied with mounting clips and cutout template.
- Basket strainer shown not included with sink.
- Basket strainers in stainless steel or matching colors available as optional accessories.
- Sinks colors available: Black, Bisque, White, Concrete, Brown, Grey
- cUPC Certified

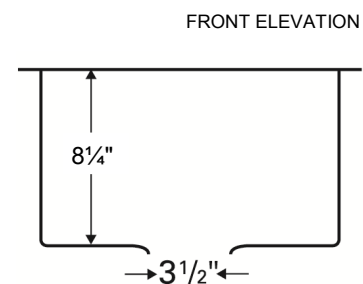
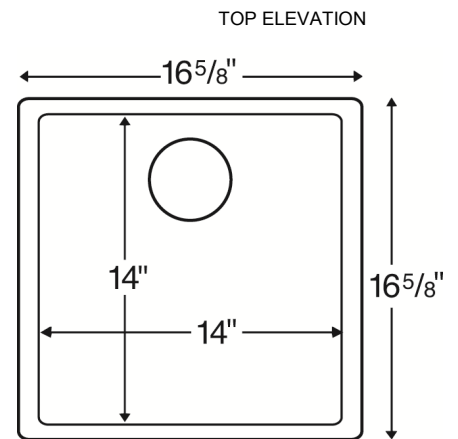

ALL DIMENSIONS ACCURATE TO 1/4"