

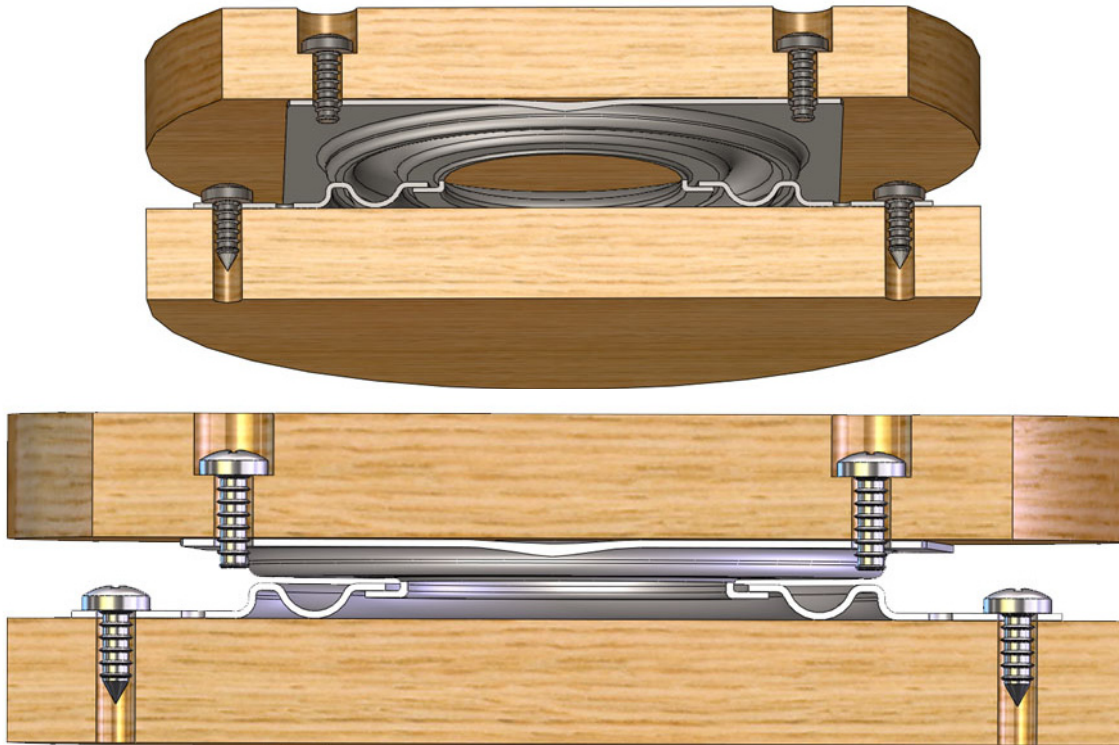

## HOW TO INSTALL TRIANGLE LAZY SUSAN BEARINGS



### **3" - 4" - 6" - 12" SIZES (WITHOUT SPEED NUTS)**

- Use the smallest holes as a template to mark the turntable for blind fastening. Remove the bearing and then drill holes for self-tapping screws. 3", 4", 6" sizes -- drill 5/32" holes for #6 self-tapping screws. 12" size-- drill 3/16" holes for #8 screws. Avoid contamination from sawdust, paint or any other foreign material.
- Lubricate the bearing balls with a small amount of heavy oil or grease. Mount the bearing on the selected center of the base using #6 wood screws.
- Assemble turning section to the bearing. Make sure to select fasteners of the proper length to avoid interference with the opposite section.

### **6" and 12" SIZES (WITH SPEED NUTS ATTACHED)**

- Use holes with speed nuts as templates to mark the turntable for blind fastening. REMOVE the bearing. Drill and countersink 7/32" holes for #10 (3/16") flat head stove bolts . Avoid contamination from sawdust, paint or any other foreign materials.
- Lubricate the bearing balls with a small amount of heavy oil or grease. Mount the bearing on the selected center of the base using #6 wood screws.
- Assemble the turning section to the bearing. make sure to select fasteners of the proper length to avoid interference with the opposite section.

Bearings can also be mounted by welding, brazing, clamping, cementing etc. With the smaller size bearings, adhesives have been successful in eliminating the need for screws and bolts. It is important to use a suitable metal to wood adhesive or cement that will not get into the ball races.